



BOMAG
FAYAT GROUP

Rubber Track Asphalt Paver **Cedarapids® CR562**



KEY FEATURES

- 16.7 ton hopper capacity
- Patented frame-raise system
- Three-point suspension system
- Direct hydrostatic drive
- Unique swinging control console
- Maximum paving width of 30 ft (9.1 m)
- Maximum paving depth of 12 in (305 mm)
- SMARTRAC rubber drive track
- Heavy-duty slat / auger conveyor system
- High alloy cast slat conveyor liners



Technical Specifications

Cedarapids® CR562

Dimensions in inches (mm)

	A	B
Frame Raised	14.75 (362)	9.5 (241)
Frame Lowered	8.75 (222)	4.25 (108)

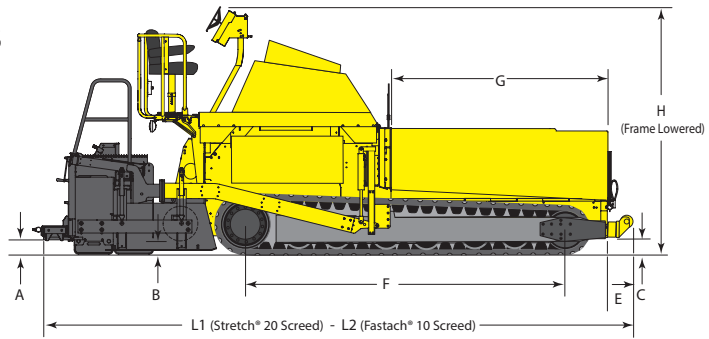

Dimensions in inches (mm)

C	E	F	G	H	L1	L2
8.5 (216)	10 (254)	128 (3251)	90 (2286)	110 (2794)	250 (6350)	239 (6071)

Standard Equipment

- Turbocharged 260 hp Tier 4i engine
- Power-tilt hood with radiator
- Lockout/tagout capable E-stop and master electrical switch
- Fume-recovery system
- Accessible filter locations
- All-welded mainframe construction
- Patented Frame Raise and Three-Point Suspension system
- Adjustable spreading auger height
- Reinforced, sealed, tilting hopper wings with beveled corners
- Hydraulically adjustable screed vibrators
- Hydraulic power crown control
- Adjustable material retaining plates
- Dual power-adjustable feed gates
- Smartrac self-tensioning track system
- Wide stance improves maneuverability
- Crawler-mounted Three-Point suspension
- Oscillating bogie wheel assemblies
- Independent hydrostatic drive for each track
- Replaceable rubber tracks
- De-tracking warning light
- Electric-over-hydraulic steering wheel control
- Operator's umbrella
- 30 ft hose reel for spray-down
- Back-up alarm

Mandatory Options (Select only one)

- Oscillating push rollers **or** Truck hitch

Optional Equipment

- Stretch® 20 screed with electric or oil heat
- Fastach® 10 screed with electric or oil heat
- Grade and slope control
- Multi-foot grade reference system
- Sonic averaging systems
- Bevel guide plates
- Cutoff shoes, 12" and 24" sections
- 500-hour filter kit
- Screed extensions
- Up time kit

Technical Data

Paver

Paver width	in (mm)	124 (3150)
Paving width (max)	ft (m)	30 (9.1)
Paving depth (max)	in (mm)	12 (305)
Paving speed (max)	ft/min (m/min)	242 (74)
Travel speed (max)	mph (kmph)	9.6 (15.4)
Track type		Replaceable rubber track
Track width	in (mm)	18 (457)
Brakes		multiple disc parking

Weights

Tractor	lbs (kg)	36415 (16518)
with Fastach® 10	lbs (kg)	40415 (18332)
with Stretch® 20	lbs (kg)	44315 (20101)

Engine

Engine manufacturer	Cummins
Type	QSB6.7
Tier Compliance	Tier 4i
Performance	hp (kW)
Speed	rpm
Electrical	V

Capacities

Diesel fuel	gal (l)	82 (310)
Hydraulic oil	gal (l)	75 (284)
Cooling system	gal (l)	6.5 (25)

Spreading Auger Sections

Construction	Cast, high alloy
Diameter	in (mm)
Thickness	in (mm)

Hopper

Length and width	in (mm)	90 (2286) x 119 (3013)
Volume	ft ³ (m ³)	267 (7.56)
Capacity	tons (tonnes)	16.7 (15)
Feed tunnel width (each)	in (mm)	30 (762)
Slat conveyor liner (thickness)	in (mm)	0.375 (9.5)

Screed

Screed plate thickness	in (mm)	0.5 (12.7)
Positive crown (hydraulically powered)	in (mm)	3 (76)
Negative crown (hydraulically powered)	in (mm)	1 (25)
Vibrations per minute (max)		3000

Screed Heaters

Stretch® 20 (electric heat) generator	kW	34
Stretch® 20 (four oil heaters) 274,000 BTU (total) gph (lph)		2 (7.6)
Fastach® 10 (electric heat) generator	kW	34
Fastach® 10 (two oil heaters) 178,000 BTU (total) gph (lph)		1.3 (4.9)

Technical modifications reserved.
Machines may be shown with options.
*Weights are based on average shipping weights.



BOMAG Americas, Inc.
2000 Kentville Rd. • Kewanee, IL 61443
Tel: 309 853-3571 • Fax: 309 852-0350