



# FIXED DECK TAG TRAILERS

TRAILER

**UBF2020**  
**UBF2022**  
**UBF2024**

**UBF2220**  
**UBF2222**  
**UBF2224**

**UBF2526**



## COVERAGE YOU CAN COUNT ON

### 2 YEAR WARRANTY

1 year standard comprehensive and 1 year extended warranty with 5 year structural at no additional cost. *Ask us for details.*

### FLEXIBLE FINANCING

Custom financing solutions available to best suit your business. *Ask us for details.*

## Worksite Tough. Operator Smart.

You asked, we delivered. The all-new Brandt Fixed Deck Tag Trailers are purpose built to tackle the challenges you face, every single day.

### ① Higher Productivity

Get on the road faster with the versatility and speed of Brandt Tag Trailers.

- Standard D-rings spaced every 48" and optional additional D-rings spaced every 24" provide more load securement points.
- Optimized design with cambered beams delivers a low tare weight for heavier loads.
- Extended enclosed toolbox and chain basked come standard in the A-frame, offering convenient access and secure storage for essential supplies.

### ② Increased Uptime

High-quality construction and rapid connection points ensure maximum uptime.

- Customize your trailer to suit your needs with weld-on features suitable for unique applications.
- Air controls are protected in the frame, ensuring longer component life and easy operator access.
- Wheel covers are built with ¼" high-strength steel for superior resistance to sagging and consistent tire clearance over years of demanding work.

### ③ Lower Cost of Operation

Long-lasting components and reduced maintenance add up to serious savings.

- Premium powder coat finish ensures long-term durability, and available in customizable colours to suit your preferred style.
- Simplified electrical system features updated OEM harnessing and plug-and-play connections, eliminating the need for a junction box.
- High-quality components and strategically engineered components reduce maintenance and repair costs.

Powerful Value. **Delivered.**



# FIXED DECK TAG TRAILERS SPECIFICATIONS

## BASE UNIT KEY SPECIFICATIONS



	UBF2020   UBF2022   UBF2024	UBF2220   UBF2222   UBF2224	UBF2526
<b>RELIABILITY - RATED CAPACITY</b>			
Frame Capacity (lb)	40,000	45,000	50,000
GVWR (lb)	51,000	57,000	62,500
<b>DIMENSIONS</b>			
Overall Length (ft)	32'6"   34'6"   36'6"		38'6"
Flat Deck Length (ft)	20'   22'   24'	20'   22'   24'	26'
Beavertail Length (ft)	6'		
A-frame Length (ft)	6'6"		
Deck Width (ft)	8'6"		
Loaded Deck Height (in)	34"	34.5"	34"
<b>RAMPS</b>			
Spring Assist Ramps 6' x 24", Self Cleaning 17° Slope	<input type="radio"/>	<input type="radio"/>	<input type="radio"/>
Air Ramps with knife edge, 7'6" x 38" 14° Slope	<input type="radio"/>	<input type="radio"/>	<input type="radio"/>
Bifold paver Air Ramps with a knife edge, 11' x 48" 11° Slope	<input type="radio"/>	<input type="radio"/>	<input type="radio"/>

# FIXED DECK TAG TRAILERS DIMENSIONS

## UBF2022

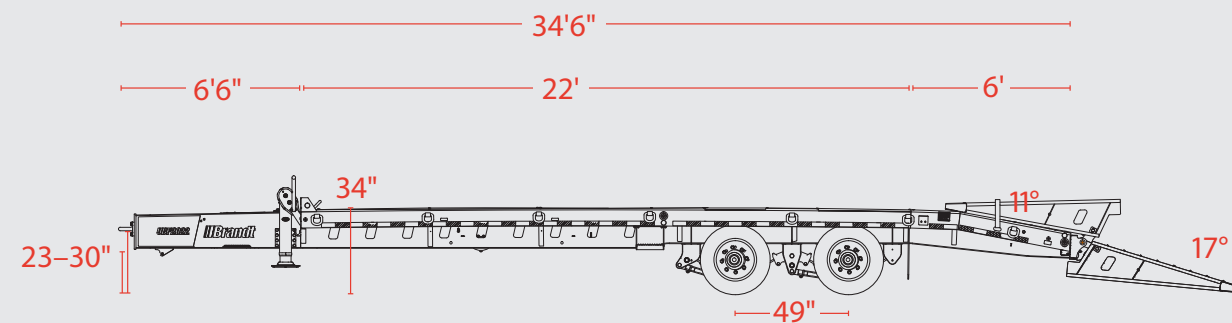

## UBF2224

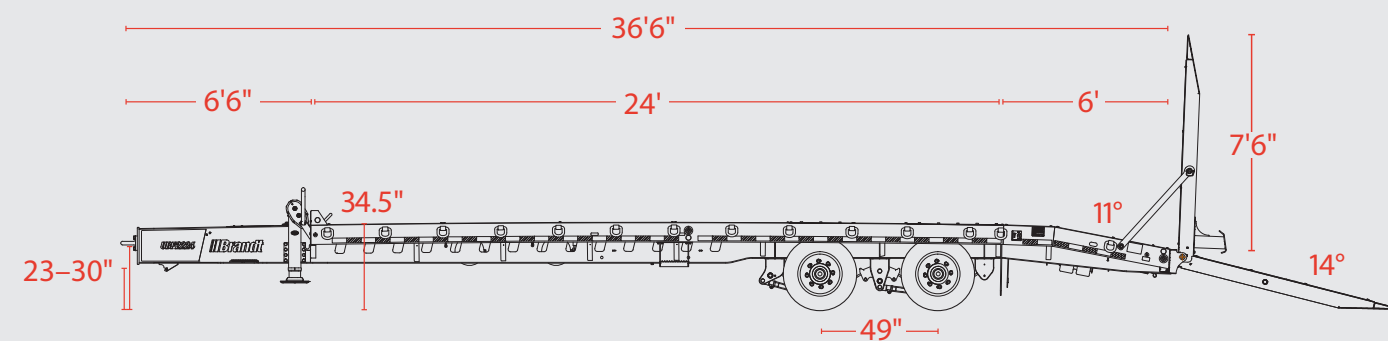

## UBF2526

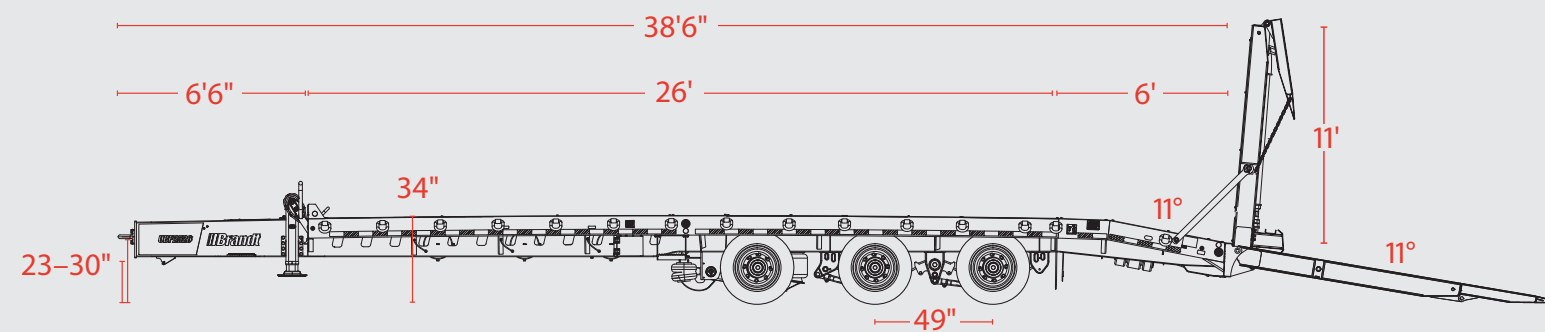

# FIXED DECK TAG TRAILERS **FEATURES**



## Engineered Beams

Cambered engineered beams enhance aesthetics and performance by reducing sag under heavy loads and providing tare weight savings.

## Air-operated Ramps With Knife Edge

These 7' 6" x 38" air ramps include a knife-edge transition and your choice of premium apitong or fir wood decking. Bolt-on legs ensure stability and long-term performance.

## Practical Design

Frequently used touchpoints including the steps, ramps, landing gear, toolbox, and tie-downs are thoughtfully designed to provide a practical and ergonomic operator experience.

## Spring-assisted, Self-cleaning Ramps

These 6' x 24" ramps feature a spring-assisted, double-hinge mechanism that supports their full weight during both deployment and storage, along with a self-cleaning design that helps prevent dirt buildup.

## Double Break Beavertail

The 6' double break beavertail reduces the loading angle, providing a smoother and more controlled experience when loading tracked equipment.

## Paver Style Air Bifold Ramps

Designed to extend before ground contact, these 11' x 45" heavy-duty air bifold ramps deliver smooth operation and superior safety. They're finished with rugged apitong decking and bolt-on legs for maximum reliability.

For more information:  
Call us at **1-888-227-2638**  
Email us at [sales@brandt.ca](mailto:sales@brandt.ca)  
Or visit us at [brandt.ca/trailers](http://brandt.ca/trailers)

© Brandt Industries Ltd. All rights reserved. The Brandt name and logo are trademarks of Brandt Industries Ltd., used under license. All product information and specifications are subject to change without notification. Printed in Canada. Revised 02/2026-CU