

250G LC

Engine	250G LC		
	Base engine for use in U.S., U.S. Territories, and Canada	Optional engine for use outside the U.S. and U.S. Territories	Optional engine for use outside the U.S., U.S. Territories, and Canada
Manufacturer and Model	John Deere PowerTech™ PVX 6.8 L	John Deere PowerTech™ Plus 6.8 L	John Deere PowerTech™ 6.8 L
Non-Road Emissions Standard	EPA Interim Tier 4/EU Stage IIIB	EPA Tier 3/EU Stage IIIA	EPA Tier 2/EPA Stage II
Net Rated Power (ISO 9249)	140 kW (188 hp) at 2,100 rpm	132 kW (177 hp) at 2,000 rpm	132 kW (177 hp) at 2,000 rpm
Cylinders	6	6	6
Displacement	6.8 L (415 cu. in.)	6.8 L (415 cu. in.)	6.8 L (415 cu. in.)
Off-Level Capacity	70% (35 deg.)	70% (35 deg.)	70% (35 deg.)
Aspiration	Turbocharged, air-to-air charge-air cooler	Turbocharged, air-to-air charge-air cooler	Turbocharged, air-to-air charge-air cooler
Cooling			
Cool-on-demand hydraulic-driven, suction-type fan with remote-mounted drive			
Powertrain			
2-speed propel with automatic shift			
Maximum Travel Speed			
Low	3.3 km/h (2.1 mph)		
High	5.5 km/h (3.4 mph)		
Drawbar Pull	22 650 kg (49,935 lb.)		
Hydraulics			
Open center, load sensing			
Main Pumps	2 variable-displacement pumps		
Maximum Rated Flow	224 L/m (59.2 gpm) x 2		
Pilot Pump	One gear		
Maximum Rated Flow	34 L/m (8.9 gpm)		
Pressure Setting	3900 kPa (566 psi)		
System Operating Pressure			
Circuits			
Implement	34 300 kPa (4,975 psi)		
Travel	35 000 kPa (5,076 psi)		
Swing	33 300 kPa (4,830 psi)		
Power Boost	38 000 kPa (5,511 psi)		
Controls	Pilot levers, short stroke, low-effort hydraulic pilot controls with shutoff lever		
Cylinders			
	<i>Bore</i>	<i>Rod Diameter</i>	<i>Stroke</i>
Boom (2)	124 mm (4.9 in.)	89 mm (3.5 in.)	1389 mm (54.7 in.)
Arm (1)	140 mm (5.5 in.)	99 mm (3.9 in.)	1610 mm (63.4 in.)
Bucket (1)	130 mm (5.1 in.)	89 mm (3.5 in.)	1074 mm (42.3 in.)
Electrical			
Number of Batteries (12 volt)	2		
Battery Capacity	1,400 CCA		
Alternator Rating	100 amp		
Work Lights	2 halogen (one mounted on boom, one on frame)		
Undercarriage			
Rollers (each side)			
Carrier	2		
Track	9		
Shoes, Triple Semi-Grousers (each side)	51		
Track			
Adjustment	Hydraulic		
Guides	2 per side		
Chain	Sealed and lubricated		



Ground Pressure **250G LC**

700-mm (28 in.) Triple Semi-Grouser Shoes	41.8 kPa (6.06 psi)
800-mm (32 in.) Triple Semi-Grouser Shoes	37.0 kPa (5.37 psi)

Swing Mechanism

Speed	13.5 rpm
Torque	74 376 Nm (54,857 lb.-ft.)

Serviceability

Refill Capacities

Fuel Tank	500 L (132 gal.)
Cooling System	23 L (6 gal.)
Engine Oil with Filter	19.5 L (5.2 gal.)
Hydraulic Tank	147.6 L (39 gal.)
Hydraulic System	240 L (63 gal.)
Swing Drive	7 L (7.5 qt.)
Gearbox	
Propel (each)	6.2 L (6.5 qt.)
Pump Drive	1.1 L (1.2 qt.)

Operating Weights

With full fuel tank; 79-kg (175 lb.) operator; 1.06-m³ (1.38 cu. yd.), 1065-mm (42 in.), 997-kg (2,197 lb.) bucket; 3.61-m (11 ft. 10 in.) arm; 5112-kg (11,270 lb.) counterweight; and 800-mm (32 in.) triple semi-grouser shoes

Operating Weight	25 281 kg (55,736 lb.)
------------------	------------------------

Component Weights

Undercarriage with Triple Semi-Grouser Shoes	
700 mm (28 in.)	8467 kg (18,667 lb.)
800 mm (32 in.)	8752 kg (19,294 lb.)
One-Piece Boom (with arm cylinder)	2210 kg (4,872 lb.)
Arm with Bucket Cylinder and Linkage	
2.96 m (9 ft. 9 in.)	1296 kg (2,858 lb.)
3.61 m (11 ft. 10 in.)	1396 kg (3,078 lb.)
Boom-Lift Cylinders (2), Total Weight	434 kg (958 lb.)
1.06-m ³ (1.38 cu. yd.), 1065-mm (42 in.) Heavy-Duty Plate-Lip Bucket	997 kg (2,197 lb.)
Counterweight, Standard	5112 kg (11,270 lb.)

Operating Dimensions

Arm Length		2.96 m (9 ft. 9 in.)	3.61 m (11 ft. 10 in.)
Arm Digging Force			
SAE		129.1 kN (29,021 lb.)	112.2 kN (25,220 lb.)
ISO		131.0 kN (29,450 lb.)	114.0 kN (25,628 lb.)
Bucket Digging Force			
SAE		175.9 kN (39,552 lb.)	175.9 kN (39,552 lb.)
ISO		189.0 kN (42,489 lb.)	189.0 kN (42,489 lb.)
Lifting Capacity Over Front at Ground Level 6.1-m (20 ft.) Reach (with power boost)		8455 kg (18,639 lb.)	8381 kg (18,478 lb.)
A	Maximum Reach	10.29 m (33 ft. 9 in.)	10.91 m (35 ft. 10 in.)
A'	Maximum Reach at Ground Level	10.11 m (33 ft. 2 in.)	10.75 m (35 ft. 3 in.)
B	Maximum Digging Depth	6.96 m (22 ft. 10 in.)	7.61 m (25 ft. 0 in.)
B'	Maximum Digging Depth at 2.44-m (8 ft. 0 in.) Flat Bottom	6.75 m (22 ft. 2 in.)	7.44 m (24 ft. 5 in.)
C	Maximum Cutting Height	10.16 m (33 ft. 4 in.)	10.56 m (34 ft. 8 in.)
D	Maximum Dumping Height	7.20 m (23 ft. 7 in.)	7.58 m (24 ft. 10 in.)
E	Minimum Swing Radius	3.44 m (11 ft. 3 in.)	3.43 m (11 ft. 3 in.)
F	Maximum Vertical Wall	6.03 m (19 ft. 9 in.)	6.74 m (22 ft. 1 in.)
G	Tail-Swing Radius	3.14 m (10 ft. 4 in.)	3.14 m (10 ft. 4 in.)

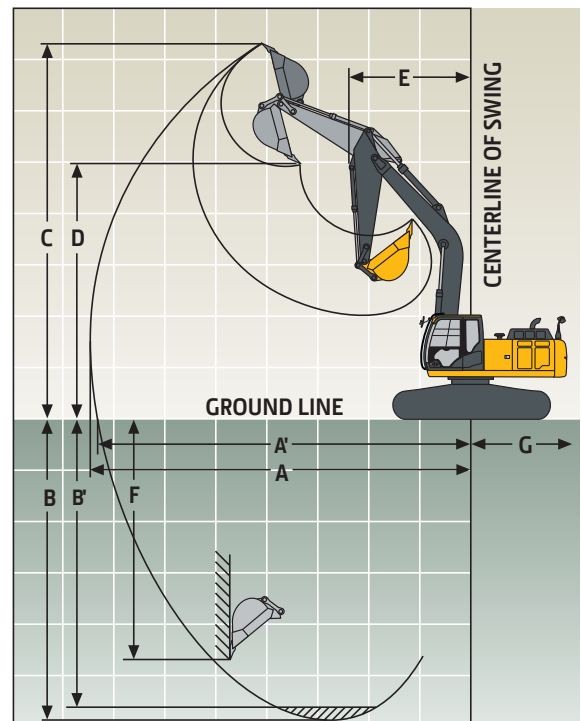

Machine Dimensions 250G LC

A Overall Length	2.96 m (9 ft. 9 in.)	10.35 m (34 ft. 0 in.)
	3.61 m (11 ft. 10 in.)	10.41 m (34 ft. 2 in.)
B Overall Height	2.96 m (9 ft. 9 in.)	3.07 m (10 ft. 1 in.)
	3.61 m (11 ft. 10 in.)	3.14 m (10 ft. 4 in.)
C Rear-End Length/Swing Radius		3.14 m (10 ft. 4 in.)
D Distance Between Idler/Sprocket Centerline		3.84 m (12 ft. 7 in.)
E Undercarriage Length		4.64 m (15 ft. 3 in.)
F Counterweight Clearance		1.09 m (3 ft. 7 in.)
G Upperstructure Width		2.89 m (9 ft. 6 in.)
H Cab Height		3.01 m (9 ft. 11 in.)
I Track Width with Triple Semi-Grouser Shoes		700 mm (28 in.) / 800 mm (32 in.)
J Gauge Width		2.59 m (8 ft. 6 in.)
K Ground Clearance		0.46 m (18 in.)
L Overall Width with Triple Semi-Grouser Shoes		
	700 mm (28 in.)	3.29 m (10 ft. 10 in.)
	800 mm (32 in.)	3.39 m (11 ft. 3 in.)

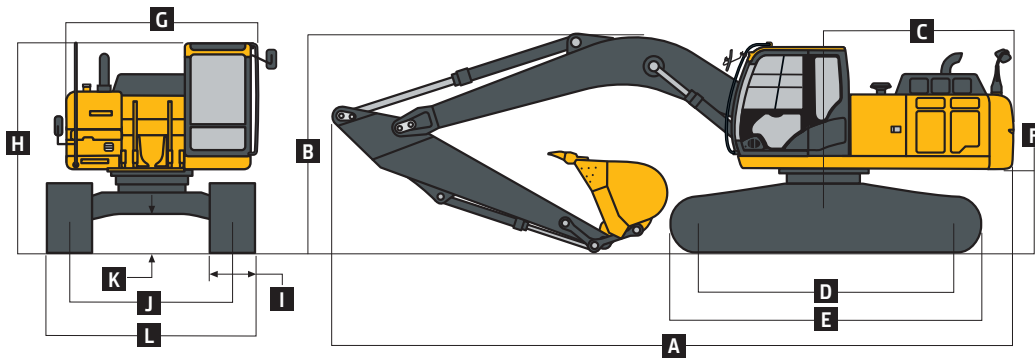

Lift Capacities

Boldface type indicates hydraulically limited capacity; **lightface type** indicates stability-limited capacities, in kg (lb.). Ratings at bucket lift hook; machine equipped with 871-kg (1,920 lb.) bucket; standard gauge; and situated on firm, uniform supporting surface. Total load includes weight of cables, hook, etc. Figures do not exceed 87 percent of hydraulic capacities or 75 percent of weight needed to tip machine. All lift capacities are based on ISO 10567.

Load Point Height	1.5 m (5 ft.)		3.0 m (10 ft.)		4.5 m (15 ft.)		6.0 m (20 ft.)		7.5 m (25 ft.)		9.0 m (30 ft.)	
	Over Front	Over Side	Over Front	Over Side	Over Front	Over Side	Over Front	Over Side	Over Front	Over Side	Over Front	Over Side
<i>With 2.96-m (9 ft. 9 in.) arm and 700-mm (28 in.) shoes</i>												
6.0 m (20 ft.)							5126	5126				
							(11,207)	(11,207)				
4.5 m (15 ft.)					7138	7138	5939	5939	5358	4155		
					(15,343)	(15,343)	(12,881)	(12,881)	(11,712)	(8,903)		
3.0 m (10 ft.)					9529	9253	7053	5839	5900	4012		
					(20,456)	(19,947)	(15,254)	(12,571)	(12,831)	(8,610)		
1.5 m (5 ft.)					11 578	8596	8135	5515	6109	3852		
					(24,945)	(18,513)	(17,591)	(11,872)	(13,128)	(8,276)		
Ground Line					12 543	8277	8576	5295	5973	3728		
					(27,129)	(17,798)	(18,423)	(11,393)	(12,839)	(8,013)		
-1.5 m (-5 ft.)			8446	8446	12 551	8201	8471	5203	5919	3679		
			(19,259)	(19,259)	(27,188)	(17,622)	(18,196)	(11,192)	(12,733)	(7,916)		
-3.0 m (-10 ft.)	9964	9964	14 599	14 599	11 732	8282	8509	5237				
	(22,420)	(22,420)	(33,304)	(33,304)	(25,372)	(17,803)	(18,290)	(11,275)				
-4.5 m (-15 ft.)			13 748	13 748	9758	8530						
			(29,522)	(29,522)	(20,866)	(18,366)						
<i>With 3.61-m (11 ft. 10 in.) arm and 700-mm (28 in.) shoes</i>												
6.0 m (20 ft.)							4380	4380	4073	4073		
							(9,584)	(9,584)	(8,643)	(8,643)		
4.5 m (15 ft.)							5228	5228	4823	4236		
							(11,347)	(11,347)	(10,535)	(9,080)		
3.0 m (10 ft.)					8377	8377	6404	5954	5440	4066	3825	2875
					(17,995)	(17,995)	(13,856)	(12,814)	(11,830)	(8,728)	(7,436)	(6,140)
1.5 m (5 ft.)					10 707	8785	7613	5589	6104	3877	4493	2792
					(23,066)	(18,917)	(16,465)	(12,027)	(13,196)	(8,327)	(8,810)	(5,971)
Ground Line			4492	4492	12 136	8327	8537	5314	5970	3720	4417	2721
			(10,371)	(10,371)	(26,233)	(17,907)	(18,478)	(11,431)	(12,828)	(7,992)	(8,130)	(5,829)
-1.5 m (-5 ft.)	4381	4381	7698	7698	12 576	8149	8438	5167	5872	3631		
	(9,836)	(9,836)	(17,525)	(17,525)	(27,229)	(17,510)	(18,120)	(11,111)	(12,622)	(7,804)		
-3.0 m (-10 ft.)	8049	8049	12 146	12 146	12 165	8158	8413	5145	5876	3635		
	(18,103)	(18,103)	(27,656)	(27,656)	(26,317)	(17,531)	(18,073)	(11,070)	(12,649)	(7,828)		
-4.5 m (-15 ft.)	12 636	12 636	15 638	15 638	10 774	8328	7773	5263				
	(28,581)	(28,581)	(33,670)	(33,670)	(23,160)	(17,916)	(16,579)	(11,351)				

Lift Capacities (continued) 250G LC

Boldface type indicates hydraulically limited capacity; lightface type indicates stability-limited capacities, in kg (lb.). Ratings at bucket lift hook; machine equipped with 871-kg (1,920 lb.) bucket; standard gauge; and situated on firm, uniform supporting surface. Total load includes weight of cables, hook, etc. Figures do not exceed 87 percent of hydraulic capacities or 75 percent of weight needed to tip machine. All lift capacities are based on ISO 10567.

Load Point Height	1.5 m (5 ft.)		3.0 m (10 ft.)		4.5 m (15 ft.)		6.0 m (20 ft.)		7.5 m (25 ft.)		9.0 m (30 ft.)	
	Over Front	Over Side	Over Front	Over Side	Over Front	Over Side	Over Front	Over Side	Over Front	Over Side	Over Front	Over Side
<i>With 2.96-m (9 ft. 9 in.) arm and 800-mm (32 in.) shoes</i>												
6.0 m (20 ft.)								5126 (11,207)	5126 (11,207)			
4.5 m (15 ft.)					7138 (15,343)	7138 (15,343)	5939 (12,881)	5939 (12,881)	5358 (11,712)	4203 (9,007)		
3.0 m (10 ft.)					9529 (20,456)	9347 (20,149)	7053 (15,254)	5902 (12,708)	5900 (12,831)	4059 (8,714)		
1.5 m (5 ft.)					11 578 (24,945)	8690 (18,716)	8135 (17,591)	5578 (12,009)	6182 (13,286)	3900 (8,380)		
Ground Line					12 543 (27,129)	8371 (18,001)	8676 (18,639)	5358 (11,530)	6046 (12,998)	3776 (8,116)		
-1.5 m (-5 ft.)			8446 (19,259)	8446 (19,259)	12 551 (27,188)	8295 (17,825)	8571 (18,413)	5266 (11,329)	5993 (12,891)	3727 (8,019)		
-3.0 m (-10 ft.)	9964 (22,420)	9964 (22,420)	14 599 (33,304)	14 599 (33,304)	11 732 (25,372)	8376 (18,005)	8588 (18,506)	5300 (11,412)				
-4.5 m (-15 ft.)			13 748 (29,522)	13 748 (29,522)	9758 (20,866)	8624 (18,568)						
<i>With 3.61-m (11 ft. 10 in.) arm and 800-mm (32 in.) shoes</i>												
6.0 m (20 ft.)								4380 (9,584)	4380 (9,584)	4073 (8,643)	4073 (8,643)	
4.5 m (15 ft.)								5228 (11,347)	5228 (11,347)	4823 (10,535)	4284 (9,184)	
3.0 m (10 ft.)					8377 (17,995)	8377 (17,995)	6404 (13,856)	6018 (12,951)	5440 (11,830)	4114 (8,831)	3825 (7,436)	2914 (6,223)
1.5 m (5 ft.)					10 707 (23,066)	8879 (19,119)	7613 (16,465)	5652 (12,164)	6104 (13,251)	3925 (8,431)	4503 (8,810)	2830 (6,055)
Ground Line			4492 (10,371)	4492 (10,371)	12 136 (26,233)	8421 (18,109)	8537 (18,478)	5378 (11,568)	6043 (12,986)	3768 (8,095)	4438 (8,130)	2759 (5,912)
-1.5 m (-5 ft.)	4381 (9836)	4381 (9836)	7698 (17,525)	7698 (17,525)	12 576 (27,229)	8243 (17,712)	8538 (18,336)	5230 (11,248)	5945 (12,780)	3679 (7,907)		
-3.0 m (-10 ft.)	8049 (18,103)	8049 (18,103)	12 146 (27,656)	12 146 (27,656)	12 165 (26,317)	8252 (17,734)	8513 (18,290)	5209 (11,207)	5950 (12,807)	3683 (7,932)		
-4.5 m (-15 ft.)	12 636 (25,581)	12 636 (25,581)	15 638 (33,670)	15 638 (33,670)	10 774 (23,160)	8422 (18,118)	7773 (16,579)	5327 (11,488)				

Buckets

A full line of buckets is offered to meet a wide variety of applications. Digging forces are with power boost. Tooth selection includes the John Deere Fanggs™ Standard, Tiger, Twin Tiger, Abrasion panel, or Flare tooth. Replaceable cutting edges and a variety of teeth are available through John Deere Parts. Optional side cutters add 150 mm (6 in.) to bucket widths. Capacities are SAE heaped ratings.

Type Bucket	Bucket Width		Bucket Capacity		Bucket Weight		Bucket Dig Force		Arm Dig Force		Arm Dig Force		Bucket Tip Radius		Number of Teeth
	mm	in.	m ³	cu. yd.	kg	lb.	kN	lb.	2.96 m (9 ft. 9 in.)	3.61 m (11 ft. 10 in.)	kN	lb.	mm	in.	
Heavy Duty	1067	42	1.06	1.4	997	2,197	176.0	39,558	129.1	29,021	112.2	25,220	1435	56.5	5
Heavy Duty	1219	48	1.22	1.6	1071	2,361	176.0	39,558	129.1	29,021	112.2	25,220	1435	56.5	6
Heavy Duty	1372	54	1.39	1.8	1138	2,509	176.0	39,558	129.1	29,021	112.2	25,220	1435	56.5	6
Heavy Duty High Capacity	610	24	0.70	0.9	801	1,767	167.4	37,636	124.7	28,044	108.9	24,477	1588	62.5	3
Heavy Duty High Capacity	760	30	0.92	1.2	913	2,012	167.4	37,636	124.7	28,044	108.9	24,477	1588	62.5	4
Heavy Duty High Capacity	914	36	1.13	1.5	968	2,135	167.4	37,636	124.7	28,044	108.9	24,477	1588	62.5	4
Heavy Duty High Capacity	1065	42	1.34	1.7	1035	2,281	167.4	37,636	124.7	28,044	108.9	24,477	1588	62.5	5
Heavy Duty High Capacity	1220	48	1.55	2.0	1137	2,507	167.4	37,636	124.7	28,044	108.9	24,477	1588	62.5	6
Ditching	1525	60	3.00	3.9	709	1,563	211.4	47,534	136.6	30,705	117.8	26,485	1194	47.0	0

Bucket Selection Guide*

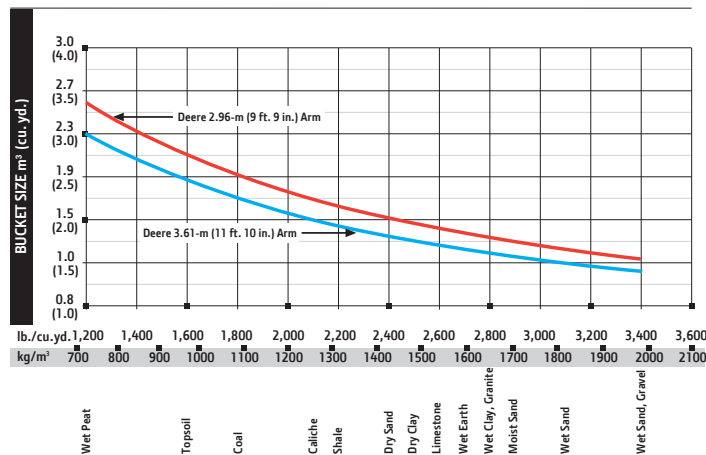

*Contact your John Deere dealer for optimum bucket and attachment selections. These recommendations are for general conditions and average use. Does not include optional equipment such as thumbs or couplers. Larger buckets may be possible when using light materials, for flat and level operations, less compacted materials, and volume loading applications such as mass-excavation applications in ideal conditions. Smaller buckets are recommended for adverse conditions such as off-level applications, rocks, and uneven surfaces. Bucket capacity indicated is SAE heaped.