

320 P

Backhoe Loader



JOHN DEERE





READY TO RUN IN THE REAL WORLD

When owners and operators just like you — the people who know what customers need for their operations to succeed — weighed in on our latest backhoe loaders, we heeded the real-world feedback. You asked for one machine that capably completes the work of two. A powerful overachiever with outstanding loader performance, backhoe capability, and multifunction versatility. And packed with productivity-elevating options including Heavy Lift (HL) to match the application. Meet the 320 P-Tier Backhoe Loader, a standout multitasker ready to run — and get more done — in any corner of the working world.

Powerful engine technology

Rugged EPA Final Tier 4 (FT4)/EU Stage IV John Deere PowerTech EWL engine boosts power, torque, and reliability compared to previous models. Simple two-valve cylinder-head, wet-sleeve design with replaceable cylinder liners provides uniform cooling and aids in reducing oil breakdown and ring wear. Filters have been redesigned and relocated for easier servicing over earlier models.

Elevated experience

Pressure-compensated, load-sensing (PCLS) hydraulics provide excellent multi-functioning, smooth machine control, and up to 15-percent greater craning capacity with Lift Mode, collectively providing a distinctive operator experience and unmatched machine performance. Trenching operation can be conducted at a lower engine rpm, reducing fuel consumption and jobsite noise.

Forward thinking

When enabled on the sealed-switch module, AutoShift automatically shifts the PowerShift™ transmission to the appropriate gear. Simply set the control lever to the highest gear desired, and the transmission will optimally shift based on engine rpm and ground speed. Included in the base machine configuration, AutoShift enhances operator ease of use during extended transport or load-and-carry applications.

Always on the move

Limited-slip mechanical-front-wheel drive (MFWD) delivers sure-footed traction in any ground condition. Engage momentary MFWD “on the fly” with a touch of a button on the loader control.

Do some heavy lifting

New Heavy Lift (HL) option includes larger rear structures and hydraulic cylinders that increase lifting capacities and breakout forces up to 25 percent.



POWERTECH™ EWL ENGINE
FEATURES RELOCATED FILTERS
FOR EASY SERVICE ACCESS

Control the ride and the load

Auto ride control eliminates the need to manually turn the feature on and off during load-and-carry applications, enhancing the operator's ease of use. When activated, front loader cylinders function as a shock absorber, smoothing the ride over rough terrain and reducing material spillage. On/Off functionality is controlled by ground speed and can be adjusted by the operator in the cab's display monitor.

Save fuel with economy mode

Standard economy mode can be configured separately between loader and backhoe functions. Activate economy mode for backhoe functions while retaining full power for loader functions. This helps maximize fuel usage in lighter-work applications with minimal effect on machine performance.

It all looks good from here

Spacious operator station is loaded with creature comforts including an efficient HVAC system, choice of adjustable mechanical or air-suspension seat, and optional premium radio with Bluetooth® and auxiliary input. Sightlines to the loader bucket corners over the sloped hood are clear.

Take it easy

Enhanced "palm-on-top" loader-control grip is intuitive and easy to use. Redesigned loader-lever linkage reduces resistance and improves its throw and feel, decreasing lever travel by up to 15 percent.

Hit the ground running

Same-side ground-level service points speed daily checks and fills. Other commonsense features such as quick-change filters, extended service intervals, simple-to-read sight gauges, and easy-access grease zerks help increase uptime.



320 P-TIER BACKHOE LOADER



AUTO RIDE CONTROL
IMPROVES THE RIDE &
MATERIAL RETENTION



Precision Construction

From grade management and obstacle detection to product automation features and jobsite intelligence, this suite of construction technology delivers productivity solutions to help you get more done, more efficiently.

John Deere construction equipment comes with in-base connectivity — free from subscriptions or annual renewals. Analyze critical machine data, track utilization, review diagnostic alerts, and more from **the John Deere Operations Center™**. The Operations Center also enables **John Deere Connected Support™**, which uses data from thousands of connected machines to proactively address issues before they arise. Your dealer can also remotely monitor machine health, diagnose problems, and even update machine software without a trip to the jobsite.*

*Availability varies by region and product. Options not available in every country.





While general information, pictures, and descriptions are provided, some illustrations and text may include product options and accessories NOT AVAILABLE in all regions, and in some countries products and accessories may require modifications or additions to ensure compliance with the local regulations of those countries.

Engine		320 P-TIER	
Manufacturer and Model	John Deere PowerTech™ EWL 4.5L turbocharged		
Non-Road Emission Standard	EPA Final Tier 4/EU Stage IV		
Displacement	4.5 L (276 cu. in.)		
Gross Peak Power	86 kW (115 hp) at 1,900 rpm		
Net Peak Power (ISO 9249)	84 kW (113 hp) at 1,900 rpm		
Net Peak Torque (ISO 9249)	459 Nm (339 lb.-ft.) at 1,600 rpm		
Net Torque Rise	30%		
Lubrication	Pressure system with spin-on filter and cooler		
Air Cleaner	Dual-stage dry type with safety element and evacuator valve		
Cooling			
Fan Type	Electronically controlled, variable-rate, suction-type cooling fan standard		
Engine Coolant Rating	-40 deg. C (-40 deg. F)		
Engine Oil Cooler	Oil to water		
Powertrain			
Transmission	5-speed, helical-cut gears, full PowerShift™ transmission with hydraulic reverser standard; electric clutch cutoff on loader lever; AutoShift transmission standard		
Torque Converter	Single stage, dual phase with 2.63:1 stall ratio, 280 mm (11 in.)		
PowerShift Standard Transmission			
Maximum Travel Speeds With Standard Engine,			
With 19.5L-24 Rear Tires	<i>Forward</i>	<i>Reverse</i>	
Gear 1	5.4 km/h (3.4 mph)	6.8 km/h (4.2 mph)	
Gear 2	10.0 km/h (6.2 mph)	12.6 km/h (7.8 mph)	
Gear 3	20.5 km/h (12.7 mph)	20.2 km/h (12.6 mph)	
Gear 4	37.3 km/h (23.2 mph)	—	
Gear 5	40.0 km/h (24.9 mph)	—	
Axles			
Axle Oscillation, Stop to Stop, Front Axle	22 deg.		
Axle Ratings	<i>Front</i>	<i>Rear</i>	
SAE J43	5500 kg (12,100 lb.)	7000 kg (15,400 lb.)	
Dynamic	9000 kg (19,800 lb.)	10 000 kg (22,000 lb.)	
Static	26 500 kg (58,400 lb.)	26 500 kg (58,400 lb.)	
Ultimate	43 500 kg (95,900 lb.)	43 500 kg (95,900 lb.)	
Differentials			
Mechanical-Front-Wheel-Drive (MFWD) Axle	Automatic, limited-slip traction control		
Rear Axle	Foot actuated, hydraulically engaged 100% mechanical lock		
Steering (ISO 5010)			
Axle	<i>MFWD</i>	<i>Non-Powered Front</i>	
Curb-Turning Radius			
With Brakes	3.52 m (11 ft. 7 in.)	3.45 m (11 ft. 4 in.)	
Without Brakes	4.02 m (13 ft. 2 in.)	3.90 m (12 ft. 10 in.)	
Bucket-Clearance Circle			
With Brakes	10.10 m (33 ft. 0 in.)	10.00 m (32 ft. 9 in.)	
Without Brakes	10.80 m (35 ft. 6 in.)	10.70 m (35 ft. 0 in.)	
Steering Wheel Turns (lock to lock)	2.6 to 3.6	3.1 to 4.3	
MFWD Axle	Heavy duty, outboard planetary final drives distribute shock loads over 3 gears		
Rear Axle	Heavy duty, outboard planetary final drives distribute shock loads over 4 gears		
Brakes (ISO 3450)			
Service	Power assisted, hydraulic wet disc, mounted inboard, self-adjusting and self-equalizing		
Parking	Spring applied, hydraulically released, wet, multi-disc, independent of service brakes with electric switch control		
Hydraulics			
Main Pump	Pressure compensated load sensing (PCLS), axial-piston pump		
Pump Flow at 2,200 rpm, Backhoe and Loader	163 L/m (43 gpm)		
System Relief Pressure			
Backhoe	24 993 kPa (3,625 psi)		
Lift Mode	27 579 kPa (4,000 psi)		
Loader	24 993 kPa (3,625 psi)		
Controls			
Backhoe	2-lever mechanical standard; pilot controls with pattern select with electrohydraulic (EH) auxiliary functions optional		
Loader	Single-lever control with electric clutch cutoff switch and MFWD (momentary) standard; single-lever control with electric clutch cutoff switch, EH proportional auxiliary roller, MFWD (momentary), and transmission quick-shift optional		

320 P-TIER BACKHOE LOADER SPECIFICATIONS

320

P

While general information, pictures, and descriptions are provided, some illustrations and text may include product options and accessories NOT AVAILABLE in all regions, and in some countries products and accessories may require modifications or additions to ensure compliance with the local regulations of those countries.

Cylinders		320 P-TIER	
Heat-treated, chrome-plated, polished rods; hardened steel (replaceable bushings) pivot pins			
	<i>Bore</i>	<i>Rod Diameter</i>	<i>Stroke</i>
Loader Boom (2)	80 mm (3.15 in.)	50 mm (1.97 in.)	789 mm (31.08 in.)
Loader Bucket (1)	90 mm (3.54 in.)	50 mm (1.97 in.)	744 mm (29.29 in.)
Backhoe Boom (1)	120 mm (4.72 in.)	56 mm (2.20 in.)	794 mm (31.26 in.)
Heavy-Lift (HL) Option	125 mm (4.92 in.)	63 mm (2.48 in.)	887 mm (34.92 in.)
Backhoe Crowd (1)	115 mm (4.53 in.)	63 mm (2.48 in.)	602.5 mm (23.72 in.)
HL Option	120 mm (4.72 in.)	63 mm (2.48 in.)	591 mm (23.27 in.)
Backhoe Bucket (1)	90 mm (3.54 in.)	56 mm (2.20 in.)	810 mm (31.89 in.)
Heavy-Duty Option	100 mm (3.94 in.)	63 mm (2.48 in.)	810 mm (31.89 in.)
HL Option	100 mm (3.94 in.)	63 mm (2.48 in.)	810 mm (31.89 in.)
Backhoe Swing (2)	90 mm (3.54 in.)	50 mm (1.97 in.)	278 mm (10.94 in.)
Backhoe Extendable Dipperstick (1)	70 mm (2.76 in.)	40 mm (1.57 in.)	1062 mm (41.81 in.)
HL Option	80 mm (3.15 in.)	45 mm (1.77 in.)	1062 mm (41.81 in.)
Backhoe Stabilizer (2)			
Standard	90 mm (3.54 in.)	50 mm (1.97 in.)	500 mm (19.69 in.)
Extended Optional	100 mm (3.94 in.)	50 mm (1.97 in.)	500 mm (19.69 in.)
HL Option Extended	100 mm (3.94 in.)	50 mm (1.97 in.)	500 mm (19.69 in.)
Non-Powered Axle (1)	70 mm (2.76 in.)	42 mm (1.65 in.)	210 mm (8.27 in.)
MFWD (1)	65 mm (2.56 in.)	40 mm (1.57 in.)	210 mm (8.27 in.)
Electrical			
Voltage	12 volt		
Alternator Rating	145 amp		
Lights	10 halogen: 4 front, 4 rear, and 2 side docking (32,500 candlepower each); turn signals and flashers: 2 front and 2 rear; stop- and taillights; and 2 rear reflectors; factory-installed option for 2 LED spotlights and 8 LED floodlights in lieu of standard halogen light package		
Operator Station			
Type (ISO 3471)	Fully enclosed cab, isolation mounted, ROPS/FOPS, left/right access, with molded roof; optional quarter cab (front glass only) and canopy		
Tires/Wheels			
	<i>Front</i>	<i>Rear</i>	
Non-Powered Front Axle	12.5/80-18 F3 (12)	19.5L-24 R4 (12)	
	14.5/75-16.1 F3 (16)	19.5L-24 R4 (12)	
With MFWD	12.5/80-18 I3 (12)	19.5L-24 R4 (10)	
	12.5/80-18 R4 (10)	19.5L-24 R4 (12)	
	12.5/80-18 I3 (12)	21L-24 R4 (12)	
	12.5/80-18 R4 (10)	21L-24 R4 (12)	
	340/80R18 XMCL	500/70R24 XMCL	
	340/80R18 550	500/70R24 550	
	340/80R18 580	500/70R24 580	
Serviceability			
Refill Capacities		Refill Capacities (continued)	
Cooling System		Diesel Exhaust Fluid (DEF) Tank	13.7 L (3.6 gal.)
Cab	27.5 L (29.1 qt.)	Hydraulic System	126.8 L (33.5 gal.)
Canopy	25.7 L (27.2 qt.)	Hydraulic Reservoir	45.0 L (11.9 gal.)
Rear Axle	18.0 L (19.0 qt.)	MFWD Axle	
Engine Oil (including vertical spin-on filter)	13.0 L (13.7 qt.)	Differential Housing	6.5 L (6.9 qt.)
Torque Converter and Transmission	15.1 L (16.0 qt.)	Planetary (each)	0.9 L (1.0 qt.)
Fuel Tank (with ground-level fueling)	128.7 L (34.0 gal.)		
Operating Weights		320 P-TIER	320 P-TIER HEAVY-LIFT (HL) OPTION
With Full Fuel Tank, 75-kg (165 lb.) Operator, Standard Equipment, Canopy, and Bumper		7146 kg (15,754 lb.)	7375 kg (16,571 lb.)
Typical With Cab and Extendable Dipperstick			
340-kg (750 lb.) Counterweight	7908 kg (17,434 lb.)	—	
454-kg (1,000 lb.) Counterweight	—		8320 kg (18,342 lb.)
Optional Components (weight difference between base equipment and option)			
Cab	284 kg (626 lb.)		284 kg (626 lb.)
MFWD With Tires	137 kg (302 lb.)		137 kg (302 lb.)
Extendable Dipperstick	138 kg (304 lb.)		207 kg (456 lb.)
Front Loader Coupler	145 kg (320 lb.)		145 kg (320 lb.)
Backhoe Bucket Coupler	120 kg (265 lb.)		120 kg (265 lb.)

320 P-TIER

While general information, pictures, and descriptions are provided, some illustrations and text may include product options and accessories NOT AVAILABLE in all regions, and in some countries products and accessories may require modifications or additions to ensure compliance with the local regulations of those countries.

Overall Dimensions	320 P-TIER	320 P-TIER HEAVY-LIFT (HL) OPTION
A Ground Clearance, Minimum	330 mm (13 in.)	310 mm (12 in.)
B Overall Length, Transport	7.28 m (23 ft. 11 in.)	7.37 m (24 ft. 2 in.)
C Width Over Tires	2.20 m (7 ft. 3 in.)	2.34 m (7 ft. 8 in.)
D Height to Top of ROPS/Cab	2.79 m (9 ft. 2 in.)	2.81 m (9 ft. 3 in.)
E Length From Axle to Axle		
Non-Powered Front Axle	2.16 m (7 ft. 1 in.)	2.16 m (7 ft. 1 in.)
MFWD Axle	2.19 m (7 ft. 2 in.)	2.19 m (7 ft. 2 in.)

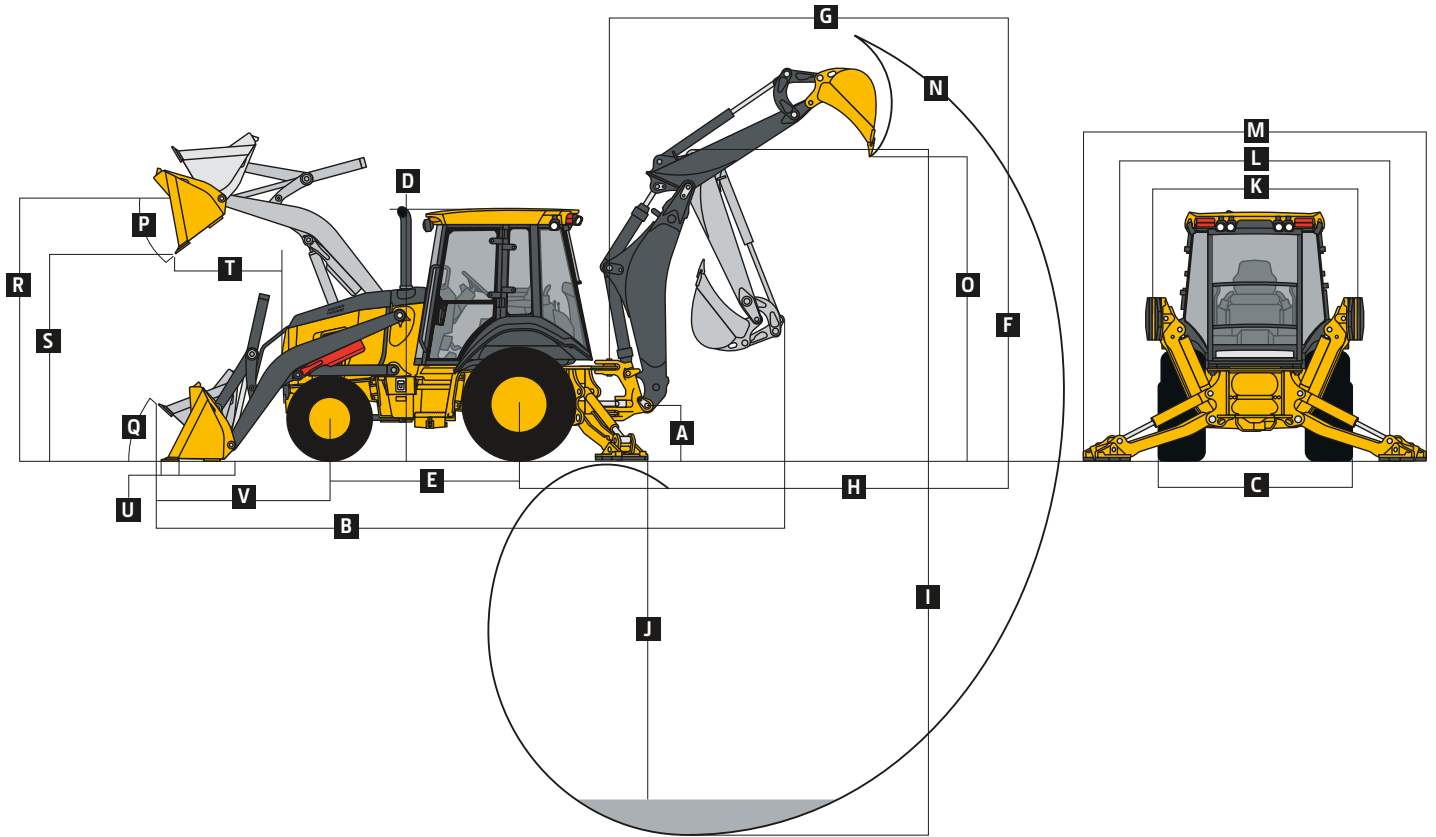

Backhoe Dimensions and Performance	320 P-TIER			320 P-TIER HL OPTION		
Backhoe specifications are with 610-mm x 0.21-m³ (24 in. x 7.5 cu. ft.) bucket; dipper lift specs are with a boom angle of 65 deg.						
Bucket Range	305–610 mm (12–24 in.)			305–610 mm (12–24 in.)		
Digging Force						
Bucket Cylinder	55.0 kN (12,356 lb.)			69.9 kN (15,723 lb.)		
Lift Mode	60.6 kN (13,634 lb.)			77.2 kN (17,349 lb.)		
With Heavy-Duty Cylinder Option	67.9 kN (15,254 lb.)			—		
Lift Mode	74.9 kN (16,832 lb.)			—		
Crowd Cylinder	36.6 kN (8,229 lb.)			38.2 kN (8,581 lb.)		
Lift Mode	40.4 kN (9,080 lb.)			42.1 kN (9,468 lb.)		
Swing Arc	180 deg.			180 deg.		
Operator Control	2 levers			2 levers		
	<i>With Optional Extendable Dipperstick</i>			<i>With Optional Extendable Dipperstick</i>		
	<i>With Standard</i>			<i>With Standard</i>		
	<i>Backhoe</i>	<i>Retracted</i>	<i>Extended</i>	<i>Backhoe</i>	<i>Retracted</i>	<i>Extended</i>
F Loading Height, Truck Loading Position	3.42 m (11 ft. 3 in.)	3.54 m (11 ft. 7 in.)	4.16 m (13 ft. 8 in.)	3.63 m (11 ft. 11 in.)	3.62 m (11 ft. 10 in.)	4.24 m (13 ft. 11 in.)
G Reach From Center of Swing Pivot	5.52 m (18 ft. 1 in.)	5.61 m (18 ft. 5 in.)	6.62 m (21 ft. 9 in.)	5.68 m (18 ft. 8 in.)	5.62 m (18 ft. 5 in.)	6.61 m (21 ft. 8 in.)
H Reach From Center of Rear Axle	6.58 m (21 ft. 7 in.)	6.68 m (21 ft. 11 in.)	7.68 m (25 ft. 2 in.)	6.74 m (22 ft. 1 in.)	6.68 m (21 ft. 11 in.)	7.67 m (25 ft. 2 in.)
I Digging Depth (SAE maximum)	4.35 m (14 ft. 3 in.)	4.50 m (14 ft. 9 in.)	5.55 m (18 ft. 2 in.)	4.59 m (15 ft. 1 in.)	4.53 m (14 ft. 10 in.)	5.53 m (18 ft. 2 in.)
J Digging Depth (SAE)						
610-mm (2 ft.) Flat Bottom	4.32 m (14 ft. 2 in.)	4.45 m (14 ft. 7 in.)	5.51 m (18 ft. 1 in.)	4.55 m (14 ft. 11 in.)	4.49 m (14 ft. 9 in.)	5.50 m (18 ft. 0 in.)
2440-mm (8 ft.) Flat Bottom	3.99 m (13 ft. 1 in.)	4.13 m (13 ft. 7 in.)	5.25 m (17 ft. 3 in.)	4.25 m (13 ft. 11 in.)	4.18 m (13 ft. 8 in.)	5.28 m (17 ft. 4 in.)
K Stabilizer Width, Transport	2.18 m (7 ft. 2 in.)	2.18 m (7 ft. 2 in.)	2.18 m (7 ft. 2 in.)	2.18 m (7 ft. 2 in.)	2.18 m (7 ft. 2 in.)	2.18 m (7 ft. 2 in.)
L Stabilizer Spread, Operating						
Standard Stabilizers	3.10 m (10 ft. 2 in.)	3.10 m (10 ft. 2 in.)	3.10 m (10 ft. 2 in.)	3.45 m (11 ft. 4 in.)	3.45 m (11 ft. 4 in.)	3.45 m (11 ft. 4 in.)
Extended Stabilizers	3.45 m (11 ft. 4 in.)	3.45 m (11 ft. 4 in.)	3.45 m (11 ft. 4 in.)	—	—	—
M Stabilizer Overall Width, Operating						
Standard Stabilizers	3.53 m (11 ft. 7 in.)	3.53 m (11 ft. 7 in.)	3.53 m (11 ft. 7 in.)	4.03 m (13 ft. 3 in.)	4.03 m (13 ft. 3 in.)	4.03 m (13 ft. 3 in.)
Extended Stabilizers	4.03 m (13 ft. 3 in.)	4.03 m (13 ft. 3 in.)	4.03 m (13 ft. 3 in.)	—	—	—

While general information, pictures, and descriptions are provided, some illustrations and text may include product options and accessories NOT AVAILABLE in all regions, and in some countries products and accessories may require modifications or additions to ensure compliance with the local regulations of those countries.

320 P-TIER

Backhoe Dimensions and Performance (continued) 320 P-TIER

320 P-TIER HEAVY-LIFT (HL) OPTION

	With Optional Extendable Dipperstick			With Optional Extendable Dipperstick		
	With Standard Backhoe			With Standard Backhoe		
	Retracted	Extended	Extended	Retracted	Extended	Extended
N Bucket Rotation	190 deg.	190 deg.	190 deg.	190 deg.	190 deg.	190 deg.
O Transport Height	3.48 m (11 ft. 5 in.)	3.49 m (11 ft. 5 in.)	3.49 m (11 ft. 5 in.)	3.56 m (11 ft. 8 in.)	3.56 m (11 ft. 8 in.)	3.56 m (11 ft. 8 in.)

Loader Dimensions and Performance [see line art on page 8]

	Heavy-duty				Heavy-duty			
	Heavy-duty	long lip	Heavy-duty	Multipurpose	Heavy-duty	long lip	Heavy-duty	Multipurpose
P Bucket Dump Angle, Maximum	45 deg.				45 deg.			
Q Rollback Angle at Ground Level	40 deg.				40 deg.			
Bucket Capacity	0.86 m ³ (1.12 cu. yd.)	0.96 m ³ (1.25 cu. yd.)	1.00 m ³ (1.31 cu. yd.)	1.00 m ³ (1.31 cu. yd.)	0.86 m ³ (1.12 cu. yd.)	0.96 m ³ (1.25 cu. yd.)	1.00 m ³ (1.31 cu. yd.)	1.00 m ³ (1.31 cu. yd.)
Width	2184 mm (86 in.)	2184 mm (86 in.)	2337 mm (92 in.)	2337 mm (92 in.)	2184 mm (86 in.)	2184 mm (86 in.)	2337 mm (92 in.)	2337 mm (92 in.)
Weight	390 kg (860 lb.)	405 kg (892 lb.)	521 kg (1,148 lb.)	863 kg (1,902 lb.)	390 kg (860 lb.)	405 kg (892 lb.)	521 kg (1,148 lb.)	863 kg (1,902 lb.)
Breakout Force	49.2 kN (11,052 lb.)	46.4 kN (10,442 lb.)	46.9 kN (10,541 lb.)	43.2 kN (9,722 lb.)	49.4 kN (11,116 lb.)	46.7 kN (10,503 lb.)	47.1 kN (10,598 lb.)	43.5 kN (9,778 lb.)
Lift Capacity, Full Height	3492 kg (7,698 lb.)	3224 kg (7,108 lb.)	3352 kg (7,390 lb.)	2862 kg (6,309 lb.)	3425 kg (7,552 lb.)	3166 kg (6,980 lb.)	3286 kg (7,244 lb.)	2801 kg (6,175 lb.)
R Height to Bucket Hinge Pin, Maximum	3.47 m (11 ft. 5 in.)	3.47 m (11 ft. 5 in.)	3.47 m (11 ft. 5 in.)	3.47 m (11 ft. 5 in.)	3.46 m (11 ft. 4 in.)	3.46 m (11 ft. 4 in.)	3.46 m (11 ft. 4 in.)	3.46 m (11 ft. 4 in.)
S Dump Clearance, Bucket at 45 deg.	2.76 m (9 ft. 1 in.)	2.66 m (8 ft. 9 in.)	2.70 m (8 ft. 10 in.)	2.67 m (8 ft. 9 in.)	2.75 m (9 ft. 0 in.)	2.65 m (8 ft. 8 in.)	2.69 m (8 ft. 10 in.)	2.66 m (8 ft. 9 in.)
T Reach at Full Height, Bucket at 45 deg.	678 mm (26.7 in.)	804 mm (31.7 in.)	675 mm (26.6 in.)	716 mm (28.2 in.)	724 mm (28.5 in.)	850 mm (33.5 in.)	720 mm (28.4 in.)	762 mm (30.0 in.)
U Digging Depth Below Ground, Bucket Level	83 mm (3.3 in.)	64 mm (2.5 in.)	128 mm (5.0 in.)	124 mm (4.9 in.)	101 mm (4.0 in.)	81 mm (3.2 in.)	145 mm (5.7 in.)	141 mm (5.6 in.)
V Length From Front Axle Centerline to Bucket Cutting Edge	1.96 m (6 ft. 5 in.)	2.10 m (6 ft. 11 in.)	2.03 m (6 ft. 8 in.)	2.08 m (6 ft. 10 in.)	1.97 m (6 ft. 6 in.)	2.11 m (6 ft. 11 in.)	2.04 m (6 ft. 8 in.)	2.09 m (6 ft. 10 in.)

Lift Capacity With Quick-Coupler Forks [see line art below]

	1219-mm (48 in.) Tines	1524-mm (60 in.) Tines	1219-mm (48 in.) Tines	1524-mm (60 in.) Tines
Hydraulic Capacity				
A ¹ Maximum Height	2067 kg (4,558 lb.)	1932 kg (4,260 lb.)	2028 kg (4,472 lb.)	1896 kg (4,180 lb.)
B ¹ Maximum Reach	3183 kg (7,017 lb.)	3001 kg (6,617 lb.)	3163 kg (6,974 lb.)	2982 kg (6,575 lb.)
C ¹ At Ground Line	4020 kg (8,863 lb.)	3768 kg (8,306 lb.)	3997 kg (8,812 lb.)	3781 kg (8,335 lb.)
D ¹ Below Ground Line	198 mm (7.8 in.)	198 mm (7.8 in.)	216 mm (8.5 in.)	216 mm (8.5 in.)

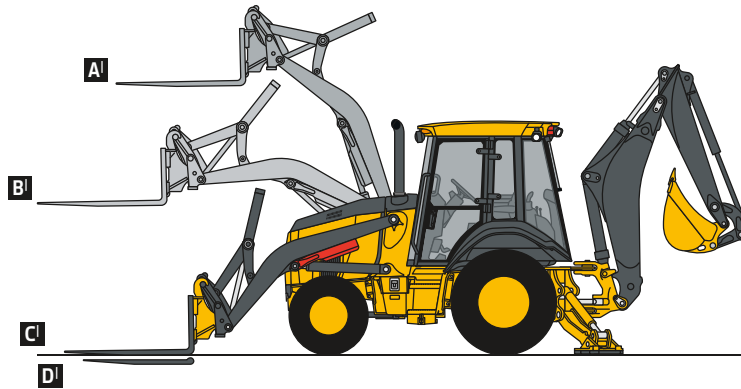

Lift Capacities [see charts on page 10]

320 P-TIER

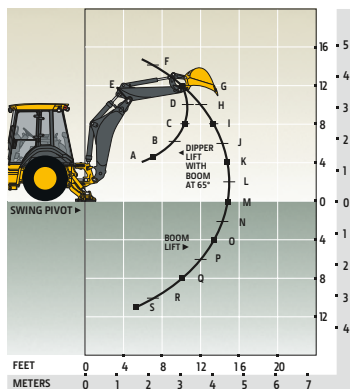

With Standard Dipperstick

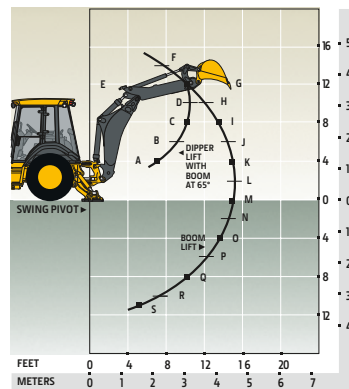

With Extendable Dipperstick, Retracted

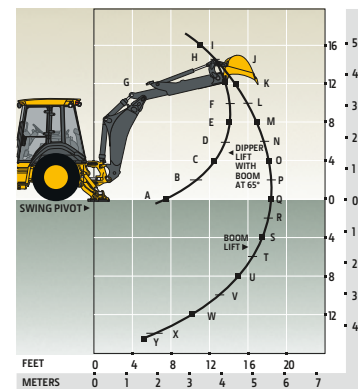

With Extendable Dipperstick, Extended

320 P-TIER

While general information, pictures, and descriptions are provided, some illustrations and text may include product options and accessories NOT AVAILABLE in all regions, and in some countries products and accessories may require modifications or additions to ensure compliance with the local regulations of those countries.

Lift Capacities (continued) [see line art on page 9]		320 P-TIER			
Lift capacities are over-end values in kg (lb.). Figures listed are 100% of the maximum lift force available.					
With Standard Dipperstick		With 1.06-m (3 ft. 6 in.) Extendable Dipperstick, Retracted		With 1.06-m (3 ft. 6 in.) Extendable Dipperstick, Extended	
Standard Lift	Lift Mode	Standard Lift	Lift Mode	Standard Lift	Lift Mode
A	4782 kg (10,543 lb.)	4858 kg (10,710 lb.)	4604 kg (10,151 lb.)	4604 kg (10,151 lb.)	3554 kg (7,834 lb.)
B	3673 kg (8,097 lb.)	3673 kg (8,097 lb.)	3251 kg (7,166 lb.)	3251 kg (7,166 lb.)	2480 kg (5,468 lb.)
C	3236 kg (7,135 lb.)	3236 kg (7,135 lb.)	2913 kg (6,423 lb.)	2913 kg (6,423 lb.)	2156 kg (4,753 lb.)
D	3168 kg (6,985 lb.)	3168 kg (6,985 lb.)	2859 kg (6,302 lb.)	2859 kg (6,302 lb.)	2012 kg (4,436 lb.)
E	3038 kg (6,698 lb.)	3364 kg (7,415 lb.)	2619 kg (5,775 lb.)	2912 kg (6,420 lb.)	1918 kg (4,228 lb.)
F	1839 kg (4,054 lb.)	2051 kg (4,522 lb.)	1488 kg (3,281 lb.)	1678 kg (3,699 lb.)	1830 kg (4,034 lb.)
G	1936 kg (4,269 lb.)	2165 kg (4,773 lb.)	1635 kg (3,604 lb.)	1846 kg (4,070 lb.)	1715 kg (3,782 lb.)
H	1918 kg (4,228 lb.)	2147 kg (4,734 lb.)	1652 kg (3,643 lb.)	1869 kg (4,120 lb.)	1525 kg (3,362 lb.)
I	1873 kg (4,128 lb.)	2099 kg (4,628 lb.)	1633 kg (3,599 lb.)	1850 kg (4,078 lb.)	1059 kg (2,334 lb.)
J	1820 kg (4,013 lb.)	2043 kg (4,504 lb.)	1599 kg (3,526 lb.)	1815 kg (4,001 lb.)	1187 kg (2,616 lb.)
K	1768 kg (3,897 lb.)	1986 kg (4,379 lb.)	1562 kg (3,443 lb.)	1775 kg (3,913 lb.)	1236 kg (2,726 lb.)
L	1717 kg (3,786 lb.)	1932 kg (4,259 lb.)	1524 kg (3,360 lb.)	1735 kg (3,825 lb.)	1253 kg (2,763 lb.)
M	1671 kg (3,685 lb.)	1882 kg (4,150 lb.)	1489 kg (3,283 lb.)	1698 kg (3,743 lb.)	1254 kg (2,765 lb.)
N	1630 kg (3,594 lb.)	1838 kg (4,053 lb.)	1458 kg (3,214 lb.)	1665 kg (3,671 lb.)	1247 kg (2,749 lb.)
O	1596 kg (3,518 lb.)	1802 kg (3,972 lb.)	1443 kg (3,160 lb.)	1640 kg (3,615 lb.)	1236 kg (2,724 lb.)
P	1571 kg (3,463 lb.)	1776 kg (3,916 lb.)	1419 kg (3,128 lb.)	1626 kg (3,585 lb.)	1223 kg (2,696 lb.)
Q	1563 kg (3,447 lb.)	1771 kg (3,904 lb.)	1424 kg (3,140 lb.)	1635 kg (3,605 lb.)	1210 kg (2,667 lb.)
R	1609 kg (3,547 lb.)	1827 kg (4,027 lb.)	1486 kg (3,276 lb.)	1710 kg (3,769 lb.)	1198 kg (2,642 lb.)
S	1735 kg (3,824 lb.)	1975 kg (4,353 lb.)	1604 kg (3,537 lb.)	1849 kg (4,076 lb.)	1190 kg (2,622 lb.)
T	—	—	—	—	1186 kg (2,614 lb.)
U	—	—	—	—	1190 kg (2,623 lb.)
V	—	—	—	—	1208 kg (2,664 lb.)
W	—	—	—	—	1261 kg (2,780 lb.)
X	—	—	—	—	1446 kg (3,188 lb.)
Y	—	—	—	—	1986 kg (4,377 lb.)

Lift capacities are over end with stabilizers down and tires tangent to ground.

Lift Capacities (continued) [see line art and charts below] 320 P-TIER HEAVY-LIFT (HL) OPTION

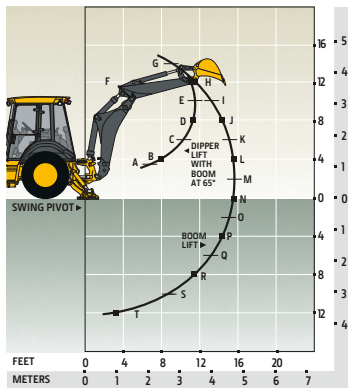

With Standard Dipperstick

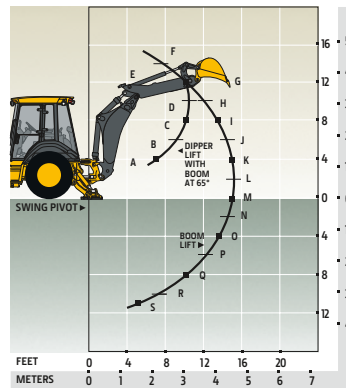

With Extendable Dipperstick, Retracted

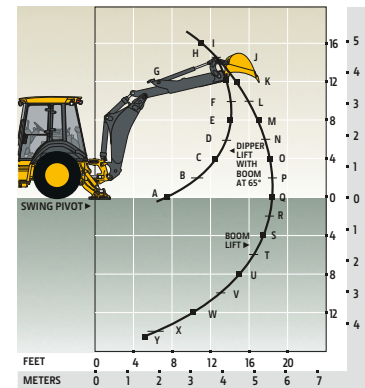

With Extendable Dipperstick, Extended

Lift capacities are over-end values in kg (lb.). Figures listed are 100% of the maximum lift force available.					
With Standard Dipperstick		With 1.06-m (3 ft. 6 in.) Extendable Dipperstick, Retracted		With 1.06-m (3 ft. 6 in.) Extendable Dipperstick, Extended	
Standard Lift	Lift Mode	Standard Lift	Lift Mode	Standard Lift	Lift Mode
A	5625 kg (12,402 lb.)	5625 kg (12,402 lb.)	5350 kg (11,795 lb.)	5350 kg (11,795 lb.)	4082 kg (8,999 lb.)
B	4697 kg (10,356 lb.)	4697 kg (10,356 lb.)	3613 kg (7,966 lb.)	3613 kg (7,966 lb.)	2709 kg (5,972 lb.)
C	3547 kg (7,819 lb.)	3547 kg (7,819 lb.)	3204 kg (7,064 lb.)	3204 kg (7,064 lb.)	2366 kg (5,216 lb.)
D	3220 kg (7,098 lb.)	3220 kg (7,098 lb.)	3122 kg (6,883 lb.)	3122 kg (6,883 lb.)	2231 kg (4,918 lb.)
E	3164 kg (6,976 lb.)	3164 kg (6,976 lb.)	3117 kg (6,871 lb.)	3282 kg (7,235 lb.)	2153 kg (4,747 lb.)
F	3095 kg (6,823 lb.)	3327 kg (7,336 lb.)	1317 kg (2,903 lb.)	1496 kg (3,297 lb.)	2088 kg (4,604 lb.)
G	1472 kg (3,244 lb.)	1645 kg (3,627 lb.)	1649 kg (3,636 lb.)	1871 kg (4,125 lb.)	2004 kg (4,418 lb.)
H	1801 kg (3,971 lb.)	2016 kg (4,445 lb.)	1744 kg (3,845 lb.)	1980 kg (4,365 lb.)	1851 kg (4,080 lb.)
I	1907 kg (4,204 lb.)	2136 kg (4,710 lb.)	1767 kg (3,896 lb.)	2008 kg (4,428 lb.)	904 kg (1,992 lb.)
J	1940 kg (4,278 lb.)	2176 kg (4,798 lb.)	1761 kg (3,883 lb.)	2004 kg (4,418 lb.)	1152 kg (2,540 lb.)
K	1944 kg (4,285 lb.)	2182 kg (4,810 lb.)	1743 kg (3,843 lb.)	1986 kg (4,378 lb.)	1267 kg (2,793 lb.)
L	1933 kg (4,262 lb.)	2172 kg (4,789 lb.)	1720 kg (3,792 lb.)	1962 kg (4,326 lb.)	1326 kg (2,923 lb.)
M	1918 kg (4,228 lb.)	2156 kg (4,754 lb.)	1698 kg (3,743 lb.)	1939 kg (4,275 lb.)	1356 kg (2,989 lb.)
N	1902 kg (4,192 lb.)	2140 kg (4,719 lb.)	1679 kg (3,702 lb.)	1921 kg (4,235 lb.)	1370 kg (3,021 lb.)
O	1889 kg (4,166 lb.)	2129 kg (4,693 lb.)	1669 kg (3,680 lb.)	1912 kg (4,215 lb.)	1376 kg (3,033 lb.)
P	1886 kg (4,157 lb.)	2126 kg (4,688 lb.)	1674 kg (3,691 lb.)	1920 kg (4,234 lb.)	1377 kg (3,035 lb.)
Q	1897 kg (4,183 lb.)	2142 kg (4,722 lb.)	1711 kg (3,773 lb.)	1965 kg (4,333 lb.)	1376 kg (3,034 lb.)
R	1941 kg (4,279 lb.)	2194 kg (4,836 lb.)	2057 kg (4,535 lb.)	2119 kg (4,671 lb.)	1376 kg (3,034 lb.)
S	2077 kg (4,578 lb.)	2350 kg (5,181 lb.)	2057 kg (4,535 lb.)	2365 kg (5,213 lb.)	1380 kg (3,042 lb.)
T	3270 kg (7,210 lb.)	3709 kg (8,176 lb.)	—	—	1390 kg (3,065 lb.)
U	—	—	—	—	1412 kg (3,113 lb.)
V	—	—	—	—	1457 kg (3,212 lb.)
W	—	—	—	—	1556 kg (3,430 lb.)
X	—	—	—	—	1873 kg (4,130 lb.)
Y	—	—	—	—	2846 kg (6,274 lb.)

Lift capacities are over end with stabilizers down and tires tangent to ground.

Additional equipment

Key: ● Standard ▲ Optional or special

See your John Deere dealer for further information.

320 P Engine

- Coolant recovery tank with low-level indicator
- Foldout, hinged cooling system
- Serpentine belt with automatic belt tensioner
- Electronically controlled, variable-rate suction-type cooling fan
- Self-cleaning exhaust aftertreatment system
- ▲ Chrome exhaust extension
- Grid heat
- ▲ 1,000-watt electric engine coolant heater
- Electronic fuel lift pump

Powertrain

- PowerShift™ transmission: Torque converter with twist-grip TCL and neutral safety switch interlock (1st through 5th gears)
- 5th-gear overdrive
- AutoShift transmission
- Transmission oil cooler
- ▲ Transmission remote oil-sampling port
- Differential lock, electric foot actuated, protection on/off (software enabled)
- Auto shutdown
- Planetary final drives
- Power-assisted hydraulic service brakes (conform to ISO 3450): Inboard, wet multi-disc, self-adjusting and self-equalizing
- Parking/emergency brake with electric switch control (conforms to ISO 3450): Spring applied, hydraulically released wet multi-disc / Independent of service brakes
- Hydrostatic power steering with emergency manual mode
- ▲ Non-powered front axle
- Mechanical-front-wheel drive (MFWD) with traction-control limited-slip differential: Electric on/off control / Sealed axle
- Automatic MFWD braking
- ▲ MFWD driveshaft guard

Backhoe

- Lift mode
- Precision mode
- Standard dipperstick digging depth
- 4.35 m (14 ft. 3 in.) [4.59 m (15 ft. 1 in.) for Heavy-Lift (HL) configuration]
- Extendable dipperstick extension
- ▲ 1.06 m (3 ft. 6 in.)
- ▲ Heavy-duty (HD) backhoe bucket cylinder (standard for HL configuration)
- ISO (Deere) 2-lever mechanical backhoe controls (not available for HL configuration)
- ▲ 2-lever pilot controls with pattern-selection feature (standard for HL configuration)
- Backhoe transport lock lever
- Swing lock pin stored in operator's station
- Stabilizers with 2-direction anti-drift valves
- ▲ Extended (long) stabilizers with reversible pads (standard for HL configuration)
- ▲ Severe-duty backhoe bucket with lift loops
- ▲ Backhoe couplers for John Deere, Case, and Cat buckets

320 P Backhoe (continued)

- ▲ Auxiliary backhoe valve with 1-way flow for hammers and compactors with plumbing
- ▲ Auxiliary backhoe valve with 1- and 2-way flow for swingers, thumbs, augers, etc. with plumbing
- ▲ Hydraulic thumb
- ▲ Rear hydraulic coupler
- ▲ Spring-type coupler

Loader¹

- Loader bucket anti-spill (rollback)
- Return-to-dig feature
- Single-lever control with electric clutch disconnect
- Bucket-level indicator
- Loader boom service lock
- Loader valve with integrated anti-drift checks for hydraulic cylinders controlling loader boom up and bucket dump
- ▲ Auxiliary loader hydraulics with single control lever with EH auxiliary control (MFWD and clutch disconnect)
- ▲ Hydraulic coupler for buckets, forks, etc.
- ▲ Auto ride control

Hydraulic System

- 163-L/m (43 gpm) axial-piston pump, pressure-compensated load-sensing (PCLS) system
- Auto-idle
- Economy mode
- Dedicated hydraulic reservoir

Electrical System

- 12-volt system
- 145-amp alternator
- Single battery with 175-min. reserve capacity and 950 CCA
- ▲ Dual batteries with 350-min. reserve capacity and 1,900 CCA
- ▲ Remote jump posts and battery disconnect

Lights

- Halogen lights (10), 32,500 candlepower each (4 front driving/working, 4 rear working, and 2 side docking)
- Turn signal/flasher (2 front and 2 rear)
- Rear stop and tail (2)
- ▲ LED light package
- ▲ Boom-light field kit (2 LED floods)

Operator's Station

- Modular-design ROPS/FOPS (Level 2) canopy with molded roof (meets ISO 3449 and ISO 3471/SAE J1040): Isolation mounted
- Molded floor mats (with pilot controls only)
- 12-volt outlet
- Lockable right-side storage
- ▲ Lockable left-hand storage with cup holders
- ▲ Interior front-view mirror
- ▲ Outside rearview mirrors
- Rotary-dial hand throttle
- Suspended foot throttle
- Mechanical-suspension seat, cloth cover
- ▲ Air-suspension heated seat (with cab only)
- ▲ Air-suspension vinyl seat

320 P Operator's Station (continued)

- Tilt steering, infinitely adjustable (with cab only)
- ▲ Tilt steering, infinitely adjustable (with canopy and quarter cab)
- Keyless start
- Machine security (enabled through monitor)
- Digital display of engine hours, engine rpm, and system voltage
- Sealed-switch module (SSM)
- Multi-function lever: Turn signals / Windshield wipers / Some light functionality
- Monitor system with audible and visual warnings: Engine air restriction / Low alternator voltage / Engine oil pressure / Hydraulic filter restriction / Parking brake on/off / Aftertreatment temperature / Transmission fluid temperature / Fuel / Hour meter / Machine diagnostic information via 4-push-button/LCD operator interface
- **Canopy:** Mechanical-suspension deluxe vinyl swivel seat with lumbar adjustment and armrests (fully adjustable)
- ▲ **Quarter Cab:** Mechanical-suspension deluxe vinyl swivel seat with lumbar adjustment and armrests (fully adjustable), front windshield, and windshield wiper (1 front)
- ▲ **Cab With Dual Doors and A/C:** Mechanical-suspension deluxe fabric swivel seat with lumbar adjustment / Headliner, dome light, left and right cab doors, tinted safety glass, windshield wipers (1 rear and 1 front), front windshield washer, fresh-air intake, and heater/defroster/pressurizer (11.7-kW [40,000 Btu/h] heater) / A/C (7.6-kW [26,000 Btu/h] output and CFC-free R134a refrigerant)
- ▲ AM/FM/weather-band (WB) radio (with cab only)
- ▲ Premium radio package (with cab only; includes additional 12-volt and USB outlets)

Overall Vehicle

- 1-piece unitized construction mainframe
- Vehicle tie-downs (2 front and 2 rear)
- Remote grease bank for front axle
- Front bumper cover
- ▲ HD front bumper
- ▲ Front counterweight – 204 kg (450 lb.), 340 kg (750 lb.), 454 kg (1,000 lb.), or 567 kg (1,250 lb.)
- ▲ Rubber grille bumpers
- Fuel tank, 128.7 L (34 gal.), ground-level fueling
- 2-position easy-tilt hood
- Extended grille frame
- Toolbox with padlock hasp
- Vandal protection for locking monitor, engine hood, toolbox, hydraulic reservoir, and fuel tank
- Reverse warning alarm
- Dent-resistant full-coverage rear fenders
- ▲ Backhoe boom-protection plate
- JDLink™ wireless communication system (available in specific countries; see your dealer for details)
- ▲ HD front grille screen
- ▲ HD stabilizer pads

¹See dealer for range of HD, multipurpose, and coupler buckets and forks.

While general information, pictures, and descriptions are provided, some illustrations and text may include product options and accessories NOT AVAILABLE in all regions, and in some countries products and accessories may require modifications or additions to ensure compliance with the local regulations of those countries.

Net engine power is with standard equipment including air cleaner, exhaust system, alternator, and cooling fan at test conditions specified per ISO 9249.

Specifications and design are subject to change without notice. Wherever applicable, specifications are in accordance with ISO standards. Except where otherwise noted, these specifications are based on a 320 P-Tier unit with 19.5L-24-in. 12PR (R4) tubeless rear and 12.5-80/18 10PR (R4) front tires, and 1.00-m³ (1.31 cu. yd.) loader bucket; and a 320 P-Tier Heavy-Lift configuration with lift mode, 19.5L-24-in. 12 PR (R4) tubeless rear and 12.5/80-18 12PR (R4) front tires, and 1.00-m³ (1.31 cu. yd.) loader bucket.



MB320PAU (23-03)



JOHN DEERE